

Smoke Alarm Device User Manual

Model number: FP510V

Thank you for purchasing our smoke alarm. Please take a few minutes to read the user's manual thoroughly and familiarise yourself and your family with its operation and save it for future reference.

Diagram 2 will help you determine the correct location of safety products that will help make your home a safer place.

Diagram 1



Product Specifications:

- **POWER:** built-in DC3V(CR123A) Lithium battery (battery not replaceable)
- **OPERATION CURRENT:** <8uA (standby), <70mA (alarm)
- **ALARM VOLUME:** >85dB(A) at 3 meters
- **ALARM SENSITIVITY:** 0.130-0.200dB/m
- **SILENCE TIME:** approx. 10 minutes
- **SMOKE ALARM DEVICE SOUND PATTERN:** ISO8201(BI 0.5s - pause 0.5s – BI 0.5s – pause 0.5s – BI 0.5s – pause 1.5s, with the red LED flash, repeat this alarm pattern.)
- **COMPLY WITH:** AS3786:2014

Description:

The unit is a photoelectric smoke alarm device. With the photoelectric technology, it is more sensitive to detecting slow smoulder fires which generally have thick, black smoke, a little heat and may smoulder for hours before bursting into flames. The smoke alarm device does not contain the radioactive material which is harmless to the environment. Smoke alarms should be installed in every room and area of the home (except the bathroom and kitchen), to ensure the everyone in the home will be able to hear and respond to the alarm sound. For minimum protection you should fit an alarm in the hallway between the living areas, bedrooms and child

rooms. Each unit shall be placed in the middle of the ceiling of each room.

Typical single storey dwelling recommended protection: Install a smoke alarm device on the ceiling or wall inside each bedroom and in the hallway outside each separate sleeping area. If a bedroom area hallway is more than 9.1m long, install a smoke alarm device at each end. If there is a basement: install a smoke alarm device on the basement ceiling at the bottom of the stairwell.

Typical multi-storey dwelling recommended protection. Install a smoke alarm device on the ceiling or wall inside each bedroom and in the hallway outside each separate sleeping area. If a bedroom area hallway is more than 9.1m long, install a smoke alarm device at each end install a smoke alarm device at the top of a first – to- second floor stairwell.

Important Safety Information:

- 1: The test button accurately tests smoke alarm device functions. Do not use any other test method. Test smoke alarm device weekly to ensure proper operation.
- 2: If you're sure it isn't a fire, open windows or fan the air around smoke alarm device for silence it
- 3: Observe and follow all local and national electrical and building codes for installation.
- 4: This smoke alarm device is designed to be used inside a single family residence only. In multi-family buildings, each individual living unit should have its own smoke alarm devices. Do not install in non-residential buildings. This smoke alarm device is not a substitute for a complete alarm system.
- 5: Install a smoke alarm device in every room and on every level of the home. Smoke may not reach the smoke alarm device for many reasons. For example, if a fire starts in a remote part of the home, on another level, in a chimney, wall, roof, or on the other side of a closed door, smoke may not reach the smoke alarm device in time to alert household members. A smoke alarm device will not promptly detect a fire except in the area or room in which it is installed.
- 6: Smoke alarm device may not alert every household member every time. The alarm horn is loud in order to alert individuals to a potential danger. However, there may be some circumstances where a household member may not hear the alarm (i.e. outdoor or indoor noise, sound sleepers, drug or alcohol usage, the hard of hearing, etc.). If you suspect that this smoke alarm device may not alert a household member, install and maintain specialty smoke alarm devices. Household members must hear the alarm's warning sound and quickly respond to it to reduce the risk of damage, injury, or death that may result from fire, If a

household member is hard of hearing, install special smoke alarm devices with lights or vibrating devices to alert occupants.

- 7: Smoke alarm devices can only sound their alarms when they detect smoke or detect combustion particles in the air. They do not sense heat, flame, or gas. This smoke alarm device is designed to give audible warning of a developing fire. However, many fires are fast - burning, explosive, or intentional, and others are caused by carelessness or safety hazards. In these circumstances smoke may not remake the unit alarm **QUICKLY ENOUGH** to ensure safe escape.
- 8: Smoke alarm devices have limitations. This smoke alarm device is not foolproof and is not warranted to protect lives or property from fire. Smoke alarm devices are not a substitute for insurance. Homeowners and renters should insure their lives and property. In addition, it is possible for the smoke alarm device to fail at any time. For this reason, you must test the smoke alarm device weekly and replace unit every 10 years.

Do Not Install Smoke alarm devices in the Following Places:

- 1: Near appliances or areas where normal combustion regularly occurs (kitchens, near furnaces, hot water heaters). Use specialised smoke alarm devices with unwanted alarm control for these areas.
- 2: In areas with high humidity, like bathrooms or areas near dishwashers or washing machines. Install at least 3m away from these areas.
- 3: Near air returns or heating and cooling supply vents. Install at least 1m away from these areas. The air could blow smoke away from the detector, interrupting its alarm.
- 4: In rooms where temperatures may fall below 5°C or rise above 45°C, or in humidity higher than 85%. These conditions will reduce battery life or cause a fault with the alarm.
- 5: In extremely dusty, dirty, or insect-infested areas particles may interfere with smoke alarm operation.

Operation:

Testing

Test the unit to ensure proper operation by pressing the test button, this will sound the alarm if the electronic circuitry, horn, and battery are working. If no alarm sounds, there is a defective battery or other failures, you can refer to “Trouble shooting” section for a solution.

DO NOT use an open flame to test your alarm, you could damage the alarm or ignite combustible materials and start a

fire.

CAUTION: Due to the loudness (85 decibels) of the alarm, always stand an arms-length away from the unit when testing. Test the alarm weekly to ensure proper operation. Erratic or low sound coming from your alarm may indicate a defective alarm, you can refer to “Trouble shooting” section for solution.

NOTE: WEEKLY TESTING IS REQUIRED.

LED indicators

Red LED-Flashing once every 40 seconds: indicates that the smoke alarm device is operating properly.

Red LED-Flashing when the test button is pressed, or when the smoke alarm device senses particles of combustion and goes into alarm (constant pulsating sound), the red LED will flash once per second. The flashing LED and pulsating alarm will continue until the air is cleared or release test button.

Red LED-Alarm silencer (Hush mode) indication: The red LED will flash once every 8 seconds, indicating the smoke alarm device is in the alarm silence (Hush) mode.

Low battery indication - An intermittent “chirp” with red LED flashes once every 40 seconds: indicates that the smoke alarm device battery is low. You may press the test button to silence alarm for 10 hours, but it will reset automatically after 10 hours.

Fault indication - The alarm chirp occurs every 40 seconds. **NOTE:** When the units chirp once every 40 seconds, you can press the test button to temporarily pause this warning tone for 10 hours. Alarm can still normally detect smoke during this period, it only removes nuisance warning tone. You can refer to “Trouble shooting” for solution. If there are still a failure, **you MUST replace it with a new alarm at once** or contact your retailer during warranty period.

Alarm silence (silence mode)

If the unit is alarming, you can push the test button, to pause the unit from alarming for approx 10 minutes. The red LED will flash once every 8 seconds, indicating the smoke alarm device is running in silence mode. Smoke alarm devices are designed to minimize nuisance alarms. Combustion particles from cooking may set off the alarm if the alarm is located close to the cooking area. Large quantities of combustible particles are generated from spills or when grilling/frying. Using the fan on a range hood that vents to outside (non-recirculating type) will also help remove these combustible particles from the kitchen. The alarm silence (test button) is extremely useful in a kitchen area or other areas prone to nuisance alarms. The silence feature is to be used only when a known alarm condition, such as smoke from cooking activates the alarm. The smoke alarm device is desensitised by pushing

the alarm test button. Silence (silence mode) on the smoke alarm device cover, the alarm will silence to indicate that the alarm is in a temporarily desensitized condition.

The smoke alarm device will automatically reset after approximately 10 minutes, if after this period, particles of combustion are still present, the alarm will sound again.

The alarm silencer (silence mode) can be repeated until the air has been cleared of the condition causing the alarm.

CAUTION: Before using the alarm silence, identify the source of the smoke and be certain a safe condition exists.

NOTE: Dense smoke will override the alarm silencer and will sound a continuous alarm again.

DANGER: If the alarm sounds, and it is not being tested, it means the unit is sensing smoke, **THE SOUND OF THE ALARM REQUIRES YOUR IMMEDIATE ATTENTION AND ACTION.**

Maintenance and Cleaning:

The alarm should be cleaned at least once a year

- To clean your alarm, remove it from bracket. You can clean it by using compressed air or a vacuum cleaner hose with a soft brush attachment. Blow or vacuum around the perimeter of the alarm to remove dust and dirt and debris. The outside of the alarm can be wiped with a damp cloth but do not use a wet cloth in order to avoid water entering the inner of alarm.
- After cleaning, reinstall it and test it by pressing the Test button. The alarm should be replaced if cleaning can't restore the alarm to normal operation.
- This alarm has a low battery monitor which will cause the alarm to "chirp" approx every 40 seconds and the red LED flash once at the same time for a minimum of thirty days when the battery gets low.
If there is a defective battery or other failures, you can refer to the "Trouble shooting" section for a solution, or deactivate this alarm to stop nuisance alarm which is caused by a failure of their function. If there are still failures during warranty, you can return it to your retailer.
Don't paint the unit. Paint will seal the vents and interfere with the sensor's ability to detect smoke.

NOTE:

1. REGULAR WEEKLY TESTING IS REQUIRED!

2. Must reactivate alarm before use if you deactivate it.

Replacing the Alarm

It is recommended this alarm should be replaced ten years from the date of manufacture. This date has been provided on the product label which is located on the back of the alarm.

WARNING: The battery is sealed in the cover and not replaceable. Please replace with another new alarm if the low battery chirp occurs.

IMPORTANT: Do not attempt to remove the cover to clean inside. This will affect warranty.

Repair:

If the alarm is not operating properly, and is still under warranty, return it to the original place of purchase. Pack it in a well-padded carton, and ship to the original place of purchase.

If the alarm is no longer under warranty, please replace it immediately with a comparable alarm.

Caution: Do not attempt to repair the alarm. It will affect your warranty.

Trouble shooting:

Problem	Trouble shooting
Smoke alarm device does not sound when tested.	<ol style="list-style-type: none"> 1. Must activate alarm before installation. 2. Clean smoke alarm device. Please refer to the "maintenance and cleaning" section. 3. If there are still failures during warranty, you can return to your retailer. 4. If the unit is out of warranty, please replace another new alarm.
The alarm "chirps" with red LED flashes once every 40 seconds.	The battery is under low battery status, please replace the smoke alarm device.
Smoke alarm device chirp occurs every 40 seconds (alarm goes into fault mode).	Clean smoke alarm device. Please refer to the "maintenance and cleaning" section. Purchase and change to another smoke alarm device if the problem still exists.
Smoke alarm device sounds, unwanted alarms intermittently or when residents are cooking, taking showers, etc.	<ol style="list-style-type: none"> 1. Press test button to pause alarm. 2. Clean smoke alarm device. Please refer to the "maintenance and cleaning" section. 3. Move smoke alarm device to new location and press test button.
The alarm sounds different from to normal. It starts and stops.	<ol style="list-style-type: none"> 1. Clean smoke alarm device. Please refer to the "maintenance and cleaning" section. 2. If there are still failures during warranty, you can return to your retailer. 3. If the unit is out of warranty, please replace with another new alarm.

How to deactivate the smoke alarm:

Press test button and hold it for about 10 seconds until LED flashes rapidly (flash 5 times per second), then press Test button rapidly at least 6 times within 5 seconds (or while LED flashes rapidly). The unit will generate a “beep” indicating the product is in inactivation mode. There will be no functions in this state. You must reactive it before use. Please refer to the chapter “installation” for activating the product

Note: Deactivate this alarm if you need to disposal it or stop nuisance alarm which is caused by a failure of their function.

Practice Fire Safety:

If the alarm sounds, and you have not pushed the test button, it is warning of a dangerous situation, your immediate response is necessary. To prepare for such occurrences, develop family escape plans, discuss them with all household members, and practice them regularly.

- 1: Expose everyone to the sound of a smoke alarm device and explain what the sound means.
- 2: Determine two exits from each room and an escape route to the outside from each exit.
- 3: Teach all household members to touch the door and use an alternate exit when the door is hot, instruct them not to open the door if the door is hot.
- 4: Teach household members to crawl along the floor to stay below dangerous smoke, fumes and gases.
- 5: Determine a safe meeting place for all members outside the building.

What to Do in Case of Fire:

- 1: Do not be panic; stay calm.
- 2: Leave the building as quickly as possible. Touch doors to feel if they are hot before opening them. Use an alternate exit if necessary. Crawl along the floor, and do not stop to collect anything.
- 3: Meet at a pre-arranged meeting place outside the building.
- 4: Call the fire department from outside the building.
- 5: Do not go back inside a burning building. Wait for the fire department to arrive.

Note: These guidelines will assist you in the event of a fire, however to reduce the chance that fires will start, practice fire safety rules and prevent hazardous situations.

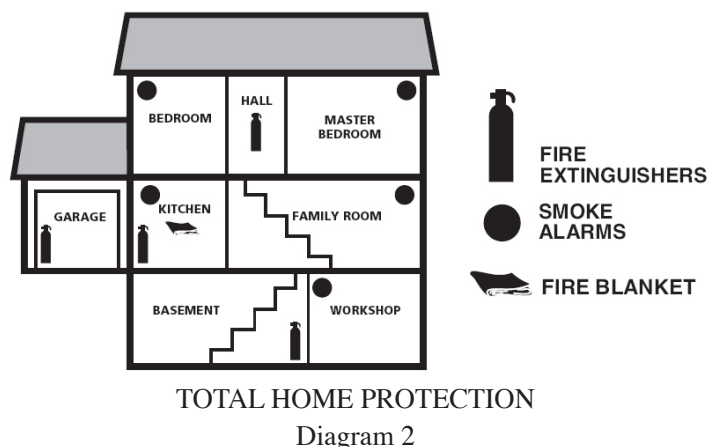

Warranty Information:

Company warrants to the original consumer that each new smoke alarm device to be free from defects in material and workmanship under normal use and service for a period of 10 years from the date of purchase. This warranty does not cover damage resulting from accident, misuse or abuse or lack of reasonable care of the product.

In no case shall company be liable for any incidental or consequential damages for breach of this or any other warranty express or implied, whatsoever. The defective product can be mailed to the address on page 6 with details explaining the problem.

Where is the best place to install alarm:

- Install the first alarm in the immediate area of the bedrooms. Install additional alarms to monitor the exit path, as the bedrooms are usually farthest from the exit. If more than one sleeping area exists, locate additional alarms in each sleeping area (see Diagram 3).
- Install additional alarms to monitor any stairway as stairways act like chimneys for smoke and heat.
- Install at least one alarm on every floor level (see Diagram 4)
- Install an alarm in every bedroom.
- Install an alarm in every room where large electrical appliances are operated (for example portable heaters).
- Install an alarm in every room where someone sleeps with the door closed. The closed door may prevent an alarm located outside from waking the sleeper.
- Smoke, heat, and combustion products rise to the ceiling and spread horizontally. Mounting the smoke alarm on the ceiling in the centre of the room places it closest to all points in the room. Ceiling mounting is preferred in ordinary residential construction.
- When mounting an alarm on the ceiling, locate it at a

minimum of 30 cm (12 in) from the side wall (see Diagram 5).

- Put smoke alarm at both ends of a bedroom hallway or large room if the hallway or room is more than 9.1 m (30 ft) long.
- Install smoke alarms on slopped, peaked or cathedral ceilings between 500 and 1500mm from the highest point of the ceiling. Smoke alarms in rooms with ceiling slopes greater than 1m in 8 m horizontally shall be located on the high side of the room (See Diagram 6)

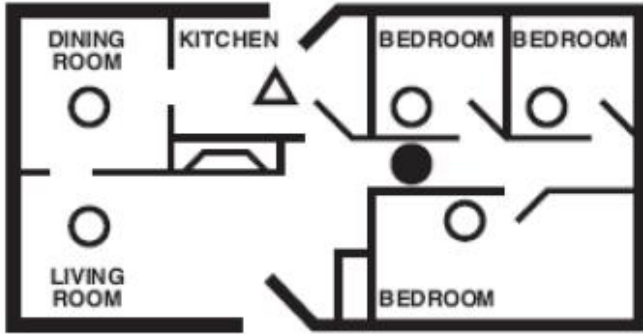

- Smoke Alarms for Minimum Protection
- Smoke Alarms for Additional Protection
- △ Ionisation Type Smoke Alarm with Alarm Silencer or Photoelectric Type

SINGLE FLOOR PLAN

Diagram 3

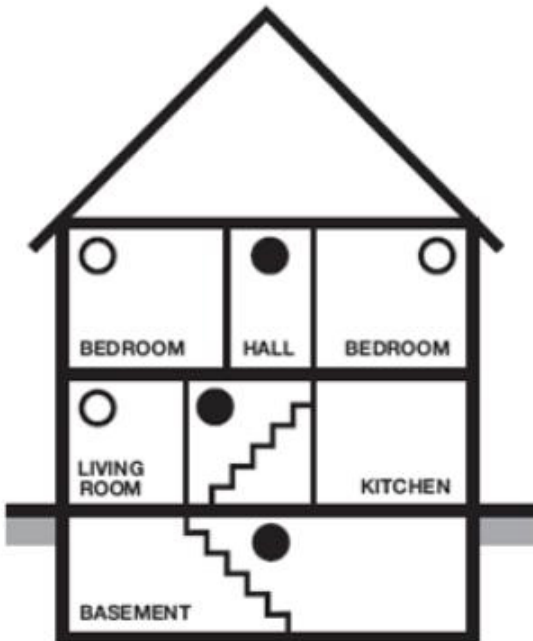

MULTIPLE FLOOR PLAN

Diagram 4

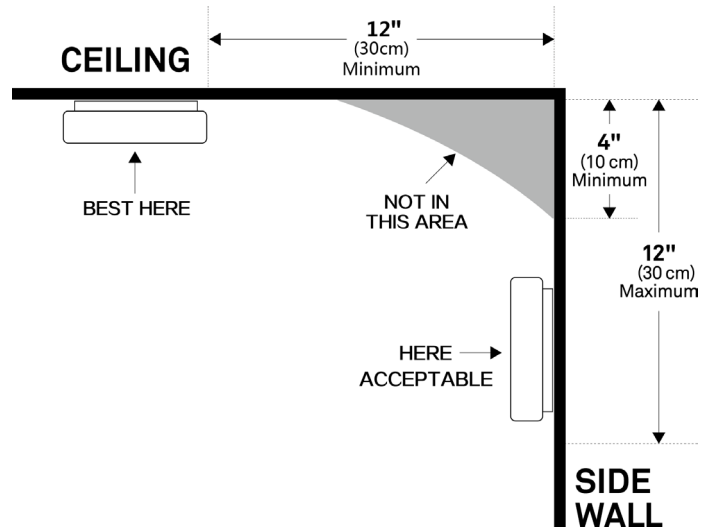
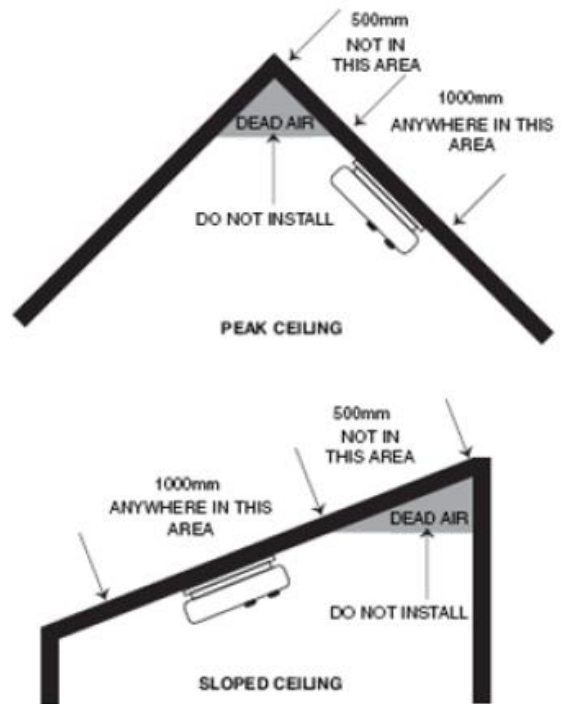

Diagram 5



Smoke alarm should be located between 500 and 1500mm from the highest point.

Diagram 6

Installation:

Activation

Press test button and hold it for about 3 seconds until LED lights, and release it within 2 seconds, the unit will generate a “beep” indicating that it is activated and is in working status

CAUTION: You MUST activate alarm first, or else there is no function for this unit.

- Turn the alarm body counterclockwise and take off the bracket.
- Place the bracket in the installation position, mark installation hole of the bracket with pencil.
- Drill two installation holes with electric drill. Make diameter of holes 5mm, Strike the two plastic plugs into holes with hammer.
- Remove fixing plug from the bracket with screwdriver if necessary (See Diagram 7).
- Attach the bracket to the plastic plugs and fix the screws tightly into the plastic plugs (See Diagram 8).
- Fit the alarm on the bracket and turn the alarm body clockwise, until matching well on the bracket.
- Insert fixing plug to the gap between bracket and bottom cover for fixing alarm if you want (See Diagram 9).
- Press the button to test the unit. The alarm sounds 3 beeps – 1.5 seconds pause, repeat it until release the button. If there is no sound, it indicates a defective alarm, you can refer to “Trouble shooting” for solution or return to your retailer during warranty.
- If you have any questions on installation, you can contact your retailer.

WARNING:

To prevent injury, this unit must be securely attached to the wall or ceiling in accordance with the installation instructions.

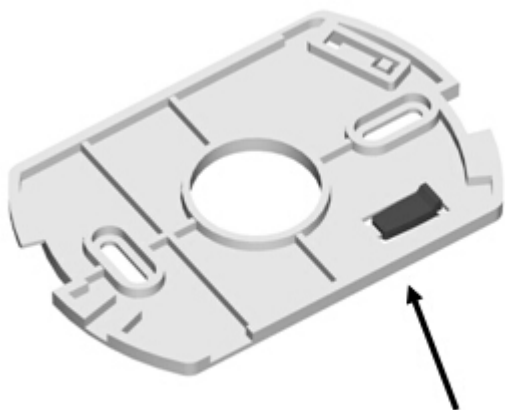

Remove the fixing plug with screwdriver

Diagram 7

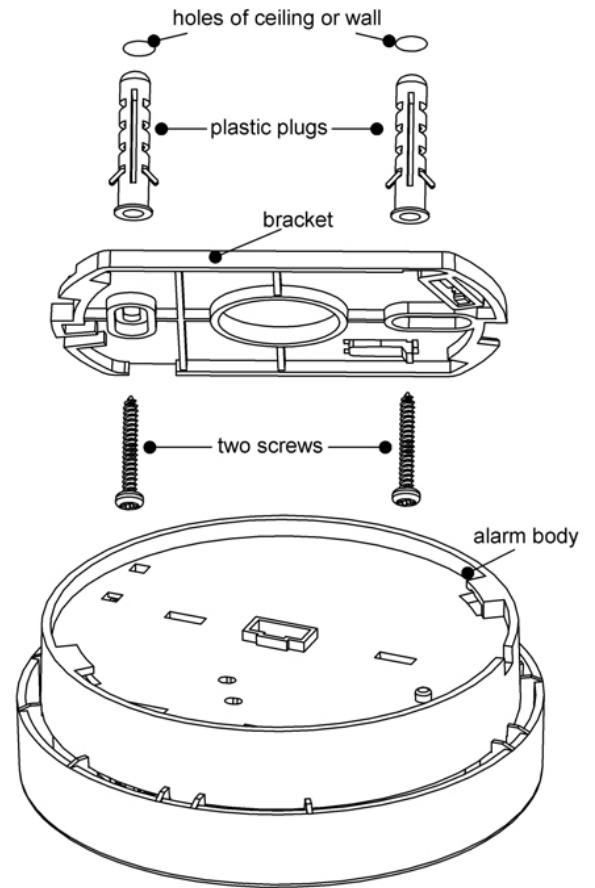

Diagram 8



Insert fixing plug

Diagram 9



FirePro

138 – 140 Bayfield Rd East,
Bayswater North, VIC, 3153.
Australia.

P (03) 9720 4333

F (03) 9720 4344

MODEL NUMBER: FP510V